



**APPROVED
UK
DISTRIBUTOR**

2-Range Torque Transducer

DRDL

Torque ranges from 0,5 to 5000 Nm
with speed and angular measurement



Features

- **2 torque ranges**
 - 1/10 - 1/2 of the 1st measuring range
- integral signal amplifier
- low moment of inertia
- single supply voltage
- wide range of applications
- contactless output signals
- no maintenance
- compact
- speed measurement (option)
- angle measurement (option)

The dual-range torque sensor is perfectly suited for use as a test-bench sensor. It is custom-built to measure **two ranges synchronously without change-over (!)**: both peak torque and operating torque are very accurately measured. A 100 % overload protection for the large load offers additional protection against transient overloads.

As the supply voltage and measurement output are transmitted without any physical contact, the device can operate continuously with negligible losses and without the need for maintenance.

The integrated measurement amplifier outputs an analog, electrically isolated 0 to ± 10 V signal per measurement range for a 12 V DC supply voltage.

The advantages of this sensor are its high torque bandwidth as well as in the reduction of change-over time and conversion costs.

The sensor is suited for measurements on electric motors, friction measurements in gearboxes, performance measurements, generator tests and automated inspection applications.



APPLIED MEASUREMENTS LTD.
Transducer Specialists...

appmeas.co.uk | info@appmeas.co.uk | +44 (0) 118 981 7339

Technical Specifications DRDL

Supply voltage:	12 V DC \pm 10 %
Current consumption:	< 200 mA
Rise time 10-90 %:	2 ms
Limit frequency -3 dB:	200 Hz
Voltage output:	0 to \pm 10 V
Internal resistance:	100 Ω
Ripple:	< 100 mVss
Nonlinearity:	< 0,1 %
Hysteresis:	< 0,1 %
Deviation at zero point:	$\leq \pm$ 100 mV
Max measurement error:	0,1 % (FS / of full scale)
Operating temperature:	0 - 60 °C
Compensated temperature range:	5 - 45 °C
Temperature error	
Zero point:	0,02 % / K
Sensitivity:	0,01 % / K
Mechanical overload:	100 %
Internal protection:	IP 40 DIN 40050
Connection:	12pin- connector
Factory calibration Right-/ left load in 25% steps. Special calibration on request.	
EMV Immunity for interference (DIN EN 61326-1 / EN 61000-6) *1	
Enclosure	Severity
HF line interference	
150 kHz - 80 MHz (AM)	10 V
ESD (Electrostatic discharge)	Air 8 kV / Kontakt 4 kV
Enclosure	
Electromagnetic Field	
80 Mhz - 1000 MHz (AM)	10 V/m
150 kHz - 80 MHz (AM)	20 V/m
Leads - Connection Cable	
Burst (fast transients)	2 kV
*1 Severity / Criterion: industrial environment; Cable length \leq 30 m. Application not outside buildings.	
Interference Emission (EN 55011)	
Disturbance Voltage (electromagnetic Disturbances)	Class B (150 kHz - 30 MHz)
Radiated Emission (electromagnetic Disruption axis)	Class B (30 MHz - 1000 MHz)

Speed Option (n)	
max. rev.:	up to 10 000 min ⁻¹ *
Output:	Open-Collektor
Internal pull up:	10 k Ω (5 V Level)
External pull up:	24 V max
I max:	20 mA
Pulses / rev.:	60
* with additional external wiring 20.000 min ⁻¹ (or speed max.)	

Angle Option (w)	
max. rev.:	up to 3 000 min ⁻¹ **
Output:	Open-Collektor
Internal pull up:	10 k Ω (5 V Level)
External pull up:	24 V max
I max:	20 mA
Pulses / rev.:	360
Resolution:	1°
Phase shift	Channel A 90° at right spin of propulsion side.
** with additional external wiring 15.000 min ⁻¹ (or speed max.)	

Mechanical Dimensions DRDL

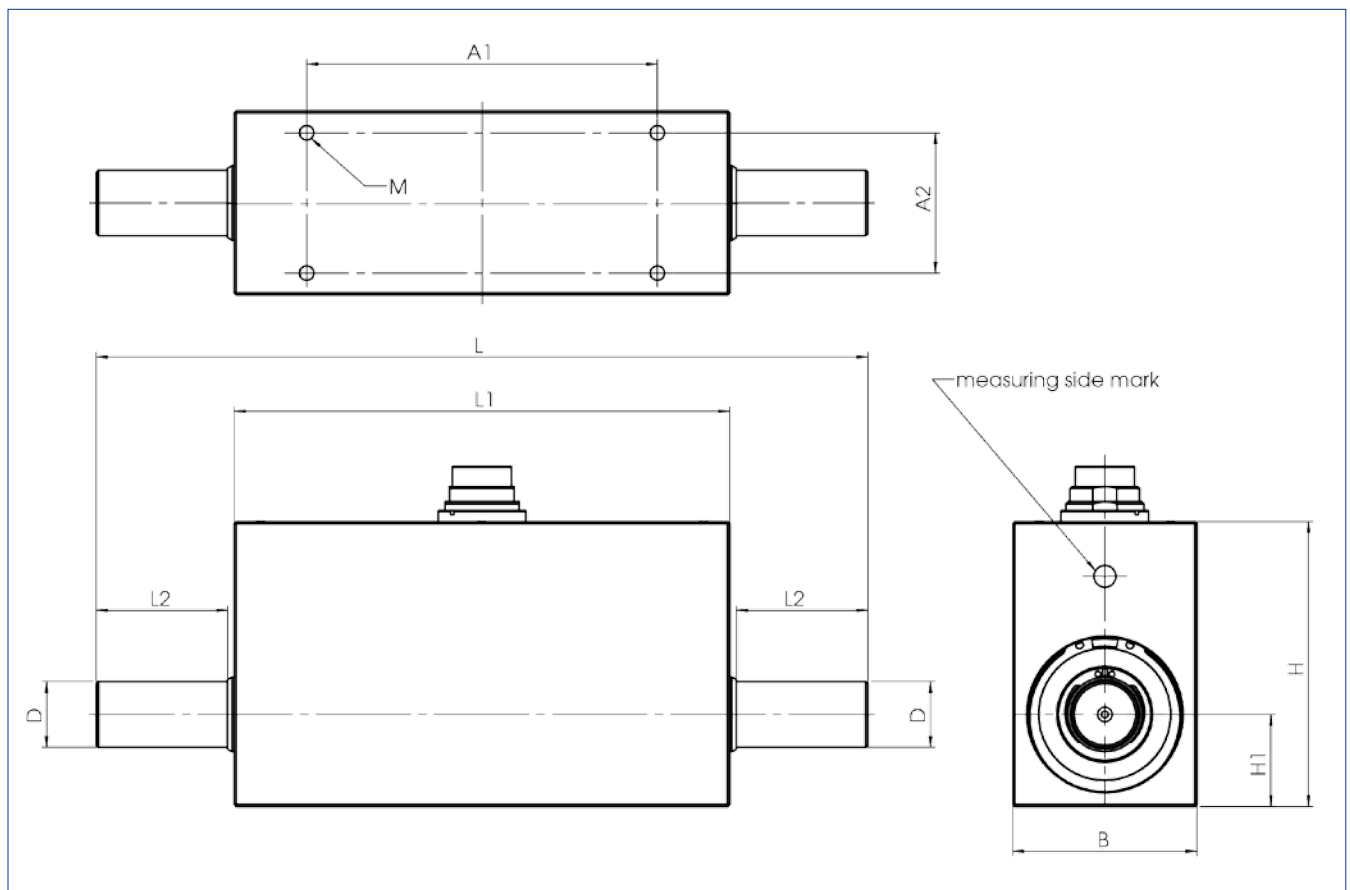

	DRDL-I	DRDL-II	DRDL-III	DRDL-IV	DRDL-V
1. Torque Range	0,5 1 2	5 10 20 50	50 100 200 300	500 1000 1500	2000 3000 4000 5000
2. Torque Range	selectable when ordering (1/10 to 1/2 of the 1st range) - other measuring ranges on request! -				
L (mm)	108	176	184	280	352
L1 (mm)	76	113	92	107	129
L2 (mm)	14	30	45	85	110
B (mm)	44	42	60	97	125
H (mm)	65	65	75	106	136
H1 (mm)	20	21	28	45	58
D g6 (∅ mm)	6	15	26	45	70
A1 (mm)	60	80	70	70	105
A2 (mm)	32	32	45	70	100
M	M3 x 6 deep	M4 x 8 deep	M5 x 10 deep	M6 x 15 deep	M8 x 16 deep
Weight approx. (g)	420	800	1500	5600	14.000
Speed max. (1/min)	36.000	19.000	13.500	7900	7900

General tolerances DIN 2768-m

Mechanical values and load limits DRDL

Size	Measuring range (Nm)	spring constant C (Nm/rad)	Mass Moment J (g•cm ²)			Permitted Axial load (N) *	Permitted Radial load (N) *
			Total	Drive side	Measuring side		
I	0,5	32	16	16	0,6	120	1,8
	1	59	18	17	1,7	280	3,4
	2	130	18	17	1,7	349	6,9
II	5	508	126	95	32	880	10
	10	1183	127	95	32	1300	20
	20	2318	128	96	32	1300	40
	50	4322	130	97	33	1300	103
III	50	9488	905	565	340	1820	77
	100	20.354	912	569	343	1820	153
	200	37.724	927	576	351	1820	309
	300	49.069	946	586	360	1820	461
IV	500	161.773	10.677	5994	4683	4560	414
	1000	280.730	10.813	6062	4751	4560	829
	1500	350.925	10.975	6143	4832	4560	1199
V	2000	881 x 10 ³	71.566	38.833	32.733	5650	6550
	3000	1176 x 10 ³	71.970	39.035	32.935	5650	9765
	4000	1385 x 10 ³	72.430	39.265	33.165	5650	11.300
	5000	1535 x 10 ³	72.931	39.516	33.415	5650	11.300

*The values for axial and radial load refer to the non-fixed housing.

Ordering Example

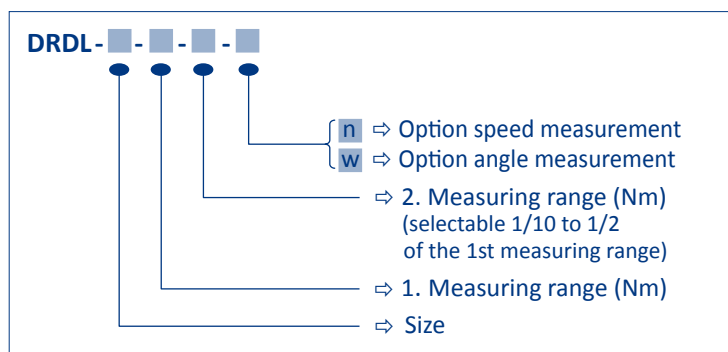

Accessories

Analyzer ValueMasterBase
Cables
Couplings



APPLIED MEASUREMENTS LTD.
Transducer Specialists...

appmeas.co.uk | info@appmeas.co.uk | +44 (0) 118 981 7339