



## T24-A01

### Wireless Telemetry Analogue Output Module

User Manual

[www.mantracourt.co.uk](http://www.mantracourt.co.uk)

**ME** mantracourt

Wireless Telemetry Range 2.4Ghz

<b>Introduction / Overview .....</b>	<b>2</b>
Communications Overview .....	2
Configuration Overview .....	3
Getting Started .....	3
Required Items .....	3
Connecting Power .....	3
T24-AO1 .....	3
T24-AO1i .....	3
<b>Configuration.....</b>	<b>4</b>
Installation .....	4
T24 Toolkit.....	4
T24-BSu Base Station .....	4
Connections and Indicators .....	4
Output Range Setting .....	5
Operation .....	5
LED Indicators.....	5
Pairing .....	5
T24 Toolkit .....	6
General Pages .....	6
Setup Base Station Communications .....	6
Home.....	7
Analyser .....	8
Information .....	9
Channel and Encryption .....	10
Save and Restore.....	11
Input / Output Config.....	12
Alarm Settings.....	14
Zero Settings .....	16
Advanced Settings .....	17
<b>Specifications .....</b>	<b>18</b>
General Radio .....	18
T24-AO1 .....	18
<b>Physical Dimensions .....</b>	<b>19</b>
T24-AO1 .....	19
T24-AO1i .....	19
<b>Installation.....</b>	<b>20</b>
Overview.....	20
<b>Approvals .....</b>	<b>21</b>
CE .....	21
FCC.....	21
Industry Canada .....	21
<b>OEM / Reseller Marking and Documentation Requirements .....</b>	<b>22</b>
FCC.....	22
IC .....	22
CE .....	22
<b>Declaration of Conformity .....</b>	<b>23</b>
<b>Worldwide Regional Approvals.....</b>	<b>23</b>
Important Note .....	23
<b>Warranty .....</b>	<b>23</b>

## Introduction / Overview

The T24-AO1 and T24-AO1i provides an analogue output for the acquisition modules such as T24-SAx and T24-SAFx. The T24-AO1i is housed in an IP67 housing for industrial installation whilst the T24-AO1 is designed for desktop mounting.

The output can be selected from the following pre-calibrated Voltage and Current ranges. 0-10Volts, +/- 10Volts, 0-5Volts, +/-5Volts, 0-20mA, 4-20mA both of which can be used in a 'sink' or source mode.

The T24-AO1 is configured by entering engineering values against the Output Minimum and Maximum Values. The analogue output is updated at a rate configured by the acquisition module's 'TXInterval'.

LEDs and, in the case of the T24-AO1i, open collector outputs, provide indication of the state of the radio link, remote battery life and remote status.

A 'Volt-free' digital Input on the T24-AO1i version allows for zeroing of the incoming data value.

The T24-AO1 is configured by the T24 Toolkit.

Version 1.1 brings the ability to wake the paired acquisition module when the analog output device is turned on and to keep it awake while it remains powered up.

## Communications Overview

The T24 range of telemetry devices each have a factory set unique **ID**.

Data is shared between devices using **Data Provider** messages. A device generates these messages which can then be used by many other devices simultaneously.

These messages (or packets) of information contain a single value of data and each is identified by a **Data Tag**. The **Data Tag** should be unique for each message.

### **ID** Identifies each device

Each device has a unique **ID** that is factory set. This is represented as a 6 character hexadecimal number consisting of the digits 0 to 9 and the letters A to F.

I.e. **FFD3BE**

### **Data Tag** Identifies each Data Provider message

A **Data Tag** consists of a 4 character hexadecimal number consisting of the digits 0 to 9 and the letters A to F. The **Data Tag** can be changed by the user but the factory default is to match the last 4 characters of the device **ID**.

I.e. An acquisition device of **ID FFC12B** would have a default **Data Tag** of **C12B**.

When a device consumes data (i.e. a handheld displaying data from an acquisition device) all it is doing is listening to all of the **Data Provider** messages and selecting the one it wants to use. It then extracts the data and displays it.

Some devices that use **Data Provider** messages also need to know the **ID** of the device providing the data. This is necessary if that device needs to specifically wake the data providing device as opposed to using a broadcast wake that will wake all devices on the same channel and using the same encryption key.

Pairing offers an automated method of hooking a provider and consumer of data together. However, some devices may require you to manually enter **Data Tag** and **ID** information so it would be beneficial to the user to understand the above mechanism.

## Configuration Overview

The T24-A01 is configured by setting the Data Tag of the device whose data you wish to reflect onto the analog output.

Once you know the data tag you then need to work out which calibrated values from the acquisition module you want represented by the selected analog output minimum and maximum levels.

For example: A T24-SA has been calibrated to give 0 to 10 tonnes output. You have selected a 4-20mA analog output and want the output to give 4mA at 0 tonnes and 20mA at 8 tonnes. Simply set the **In Minimum** to 0 and **In Maximum** to 8.

Next you set the desired actions when errors occur.

## Getting Started

### Required Items

You will need an acquisition module to provide data to the analog output. Ensure that for testing you can access the module's power supply and have some way of changing its input.

### Connecting Power

You will need to connect a power supply to the T24-A01 for it to operate and to enable configuration using a base station and the appropriate toolkit software.

Power is supplied via the screw terminals and can be in the range of 9 to 36V DC.

## T24-A01

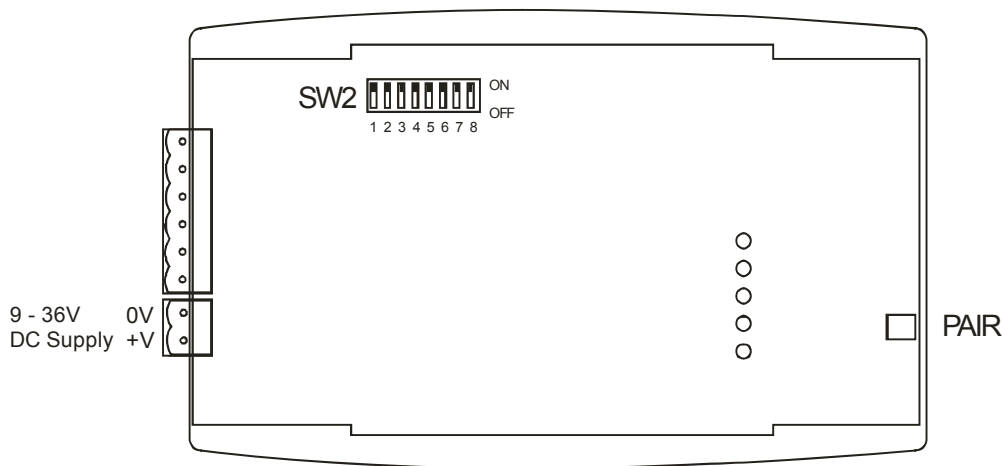

## T24-A01i

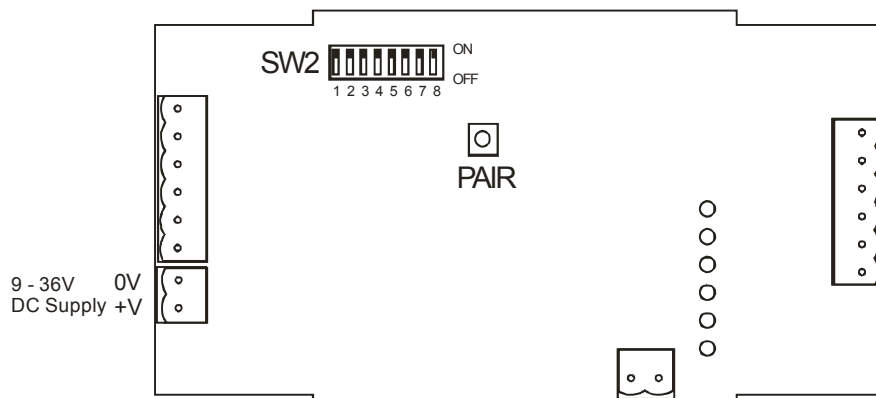

## Configuration

This section explains how to install software and connect the required devices together. Please note that you will need the T24 Toolkit software and a T24-BS base station to allow your computer to communicate with T24 telemetry devices.

## Installation

### T24 Toolkit

To configure the devices we must use the **T24 Toolkit** software application. This can be downloaded from our web site or may be shipped with your products.

Install this on a PC or laptop.

Run **setup.exe** and follow the prompts to install the software.

### T24-BSu Base Station

If you have a USB version of the base station (T24-BSu) then you just need to plug this into a USB socket on your PC. If you are using an alternative base station then please refer to the appropriate manual.

## Connections and Indicators

Depending on the analog output device you have you will need to refer to one of the two following diagrams:

### T24-A01

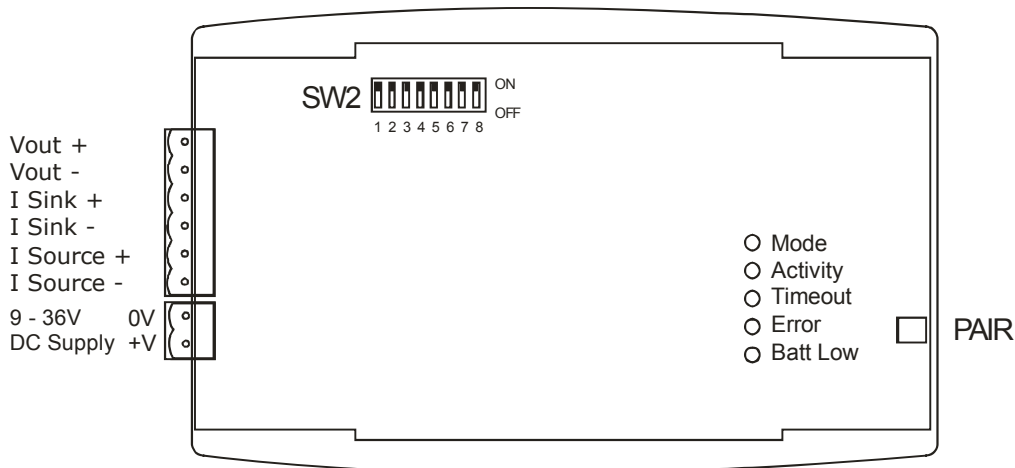

### T24-A01i

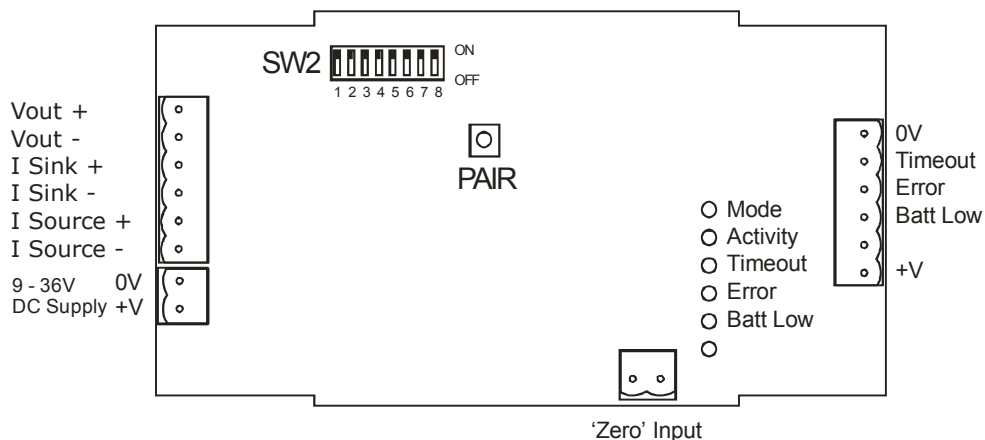

## Output Range Setting

To configure the required output range the DIP switches (SW2) require setting as follows. To access the DIP switches you will need to remove the cover from the case.

Range	SW2 Switch Settings							
	1	2	3	4	5	6	7	8
0-10 V	ON	OFF	OFF	X	X	OFF	ON	OFF
+/-10 V	OFF	OFF	ON	X	X	OFF	ON	ON
0-5 V	ON	ON	OFF	X	X	OFF	OFF	OFF
+/-5 V	ON	OFF	ON	X	X	OFF	OFF	ON
0-20 mA Sink	X	X	X	OFF	ON	ON	OFF	OFF
0-20 mA Source	X	X	X	ON	OFF	ON	ON	OFF
4-20 mA Sink	X	X	X	OFF	ON	ON	OFF	ON
4-20 mA Source	X	X	X	ON	OFF	ON	ON	ON

Where X = Don't care

## Operation

### LED Indicators

LED	Description
Mode	Flashing at 2Hz indicates normal operation. Constantly on indicates currently attempting to pair. Flashing at 4Hz indicates a failed pair attempt.
Activity	LED lights for 20ms each time data arrives. When data arrives at a rate greater than 50Hz the LED will appear constantly illuminated.
Timeout	Lost communications with the remote device.
Error	Remote device is reporting an error.
Batt Low	Remote device is reporting a low battery.

### Pairing

To associate the T24-AO1 with an acquisition device we just need to let the T24-AO1 know the Data Tag of the data to use.

This can be done manually using the T24 Toolkit (See the Advanced Settings page) or this can be achieved using the Pair button of the T24-AO1.

When first configuring the T24-AO1 it really makes no difference which technique is used but if you were replacing a data acquisition device in the field the switch technique would negate the need for the Toolkit or a base station.

To perform a 'pair' first remove the power from the acquisition device. Next, press the Pair Switch on the T24-AO1 then within 10 seconds re-apply power to the acquisition device. The mode LED will indicate the success or failure of this operation (See above table).

Note: To access the Pair Switch on a T24-AO1i you need to remove the lid. The Pair Switch can be accessed through a hole in the end of the case on a T24-AO1, a straightened paper clip could be used.

An advantage of using the Pair Switch is that you can pair to any acquisition device regardless of its radio channel or encryption key settings. When you pair the acquisition device settings will be changed to match those of the T24-AO1. If you manually enter the Data Tag using the T24-Toolkit you will need to ensure that both the acquisition module and the T24-AO1 are on the same radio channel and are using the same encryption key.

## T24 Toolkit

The T24 Toolkit provides a means of simple configuration of the T24-AO1 and associated acquisition module along with useful tools to aid integration. Calibration of the acquisition modules is also provided.

Run the T24 Toolkit software application.

### General Pages

#### Setup Base Station Communications

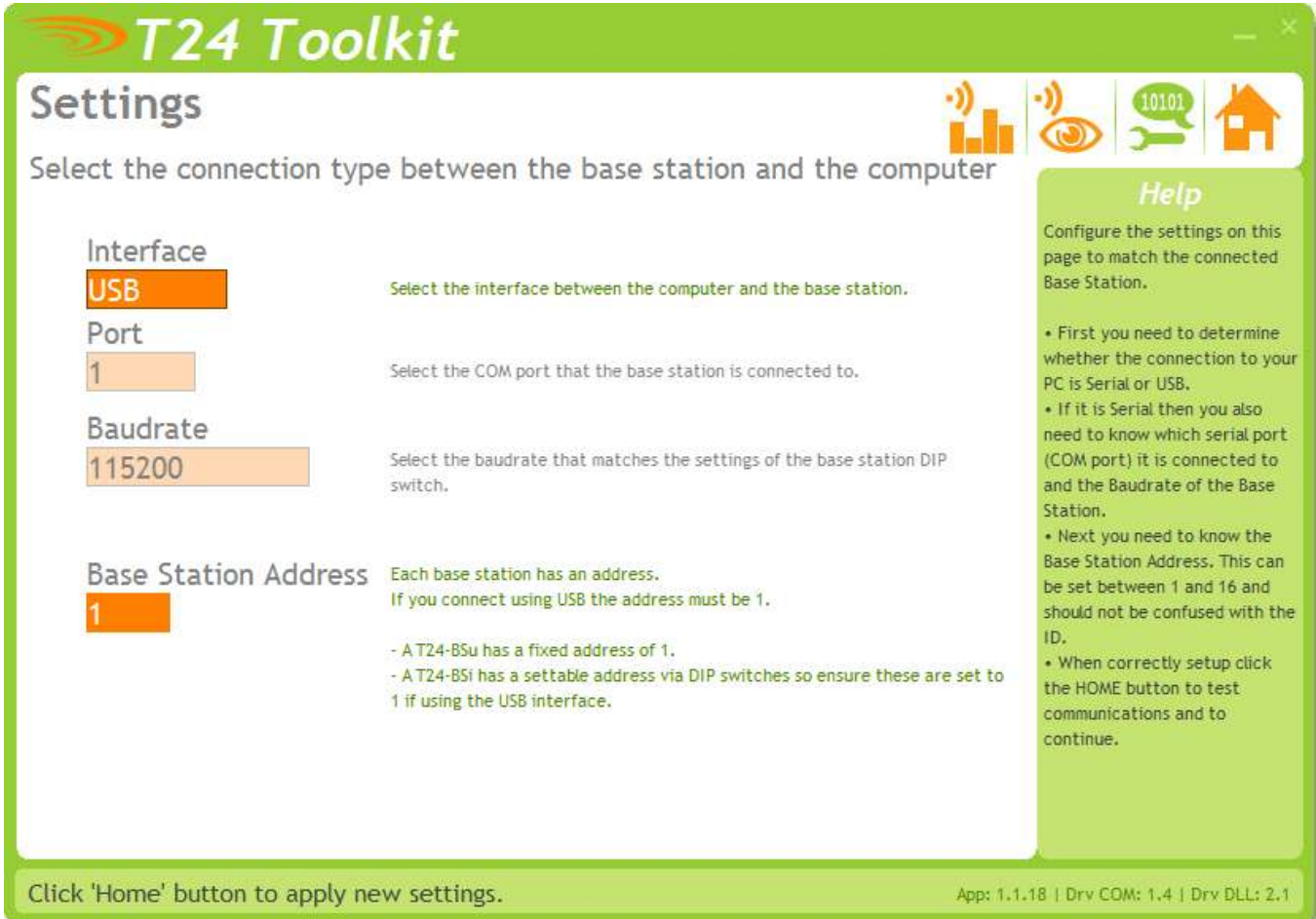

Select **USB** as the interface and select 1 as the Base Station Address. In the toolkit all items that can be changed by the user are coloured orange.

To change a value just click on the relevant orange item. You will then be presented with a new dialog window allowing you to change the value.

This may use a slider, text box or list to allow your new value to be entered.

Click the Home button to attempt communications with the base station.

If no communications can be established the toolkit will remain on this page. You will need to check that the base station is powered and that it is connected to the computer correctly.

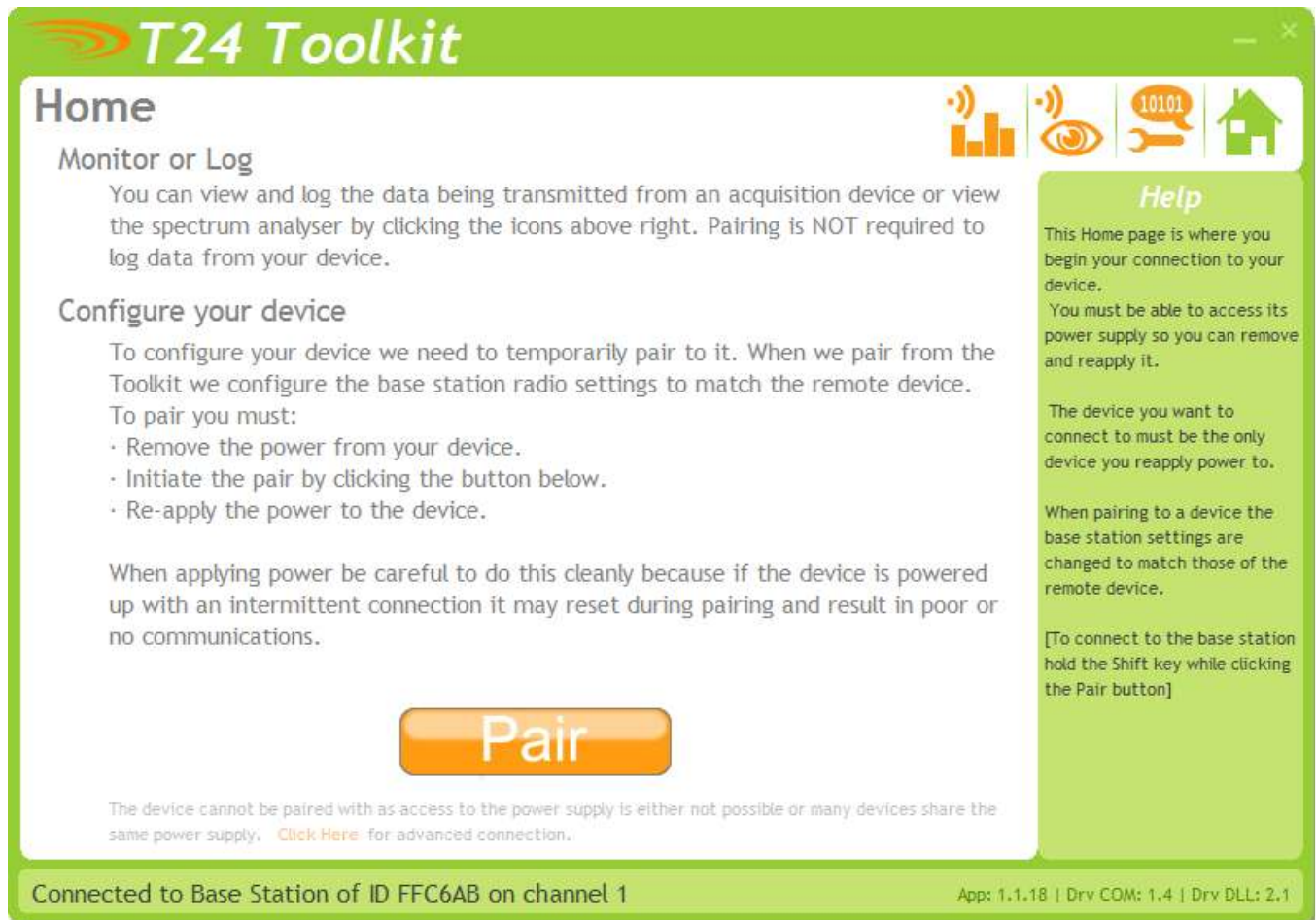

We now have successful communications with the base station so we can now pair with our device or we can select the Spectrum Analyser mode or Data Provider Monitor mode.

#### Pairing Procedure

- Remove power from the T24-AO1 module.
- Click the Pair button on the toolkit.
- You now have 10 seconds to re-apply power to the T24-AO1 module.

If you connect successfully the toolkit will change to the Information page.  
If the pairing fails try again.

---

**NOTE:** The act of Pairing with the toolkit will **not** change the radio configuration settings of the connected device. The settings will only change if you change them yourself within the toolkit.

---



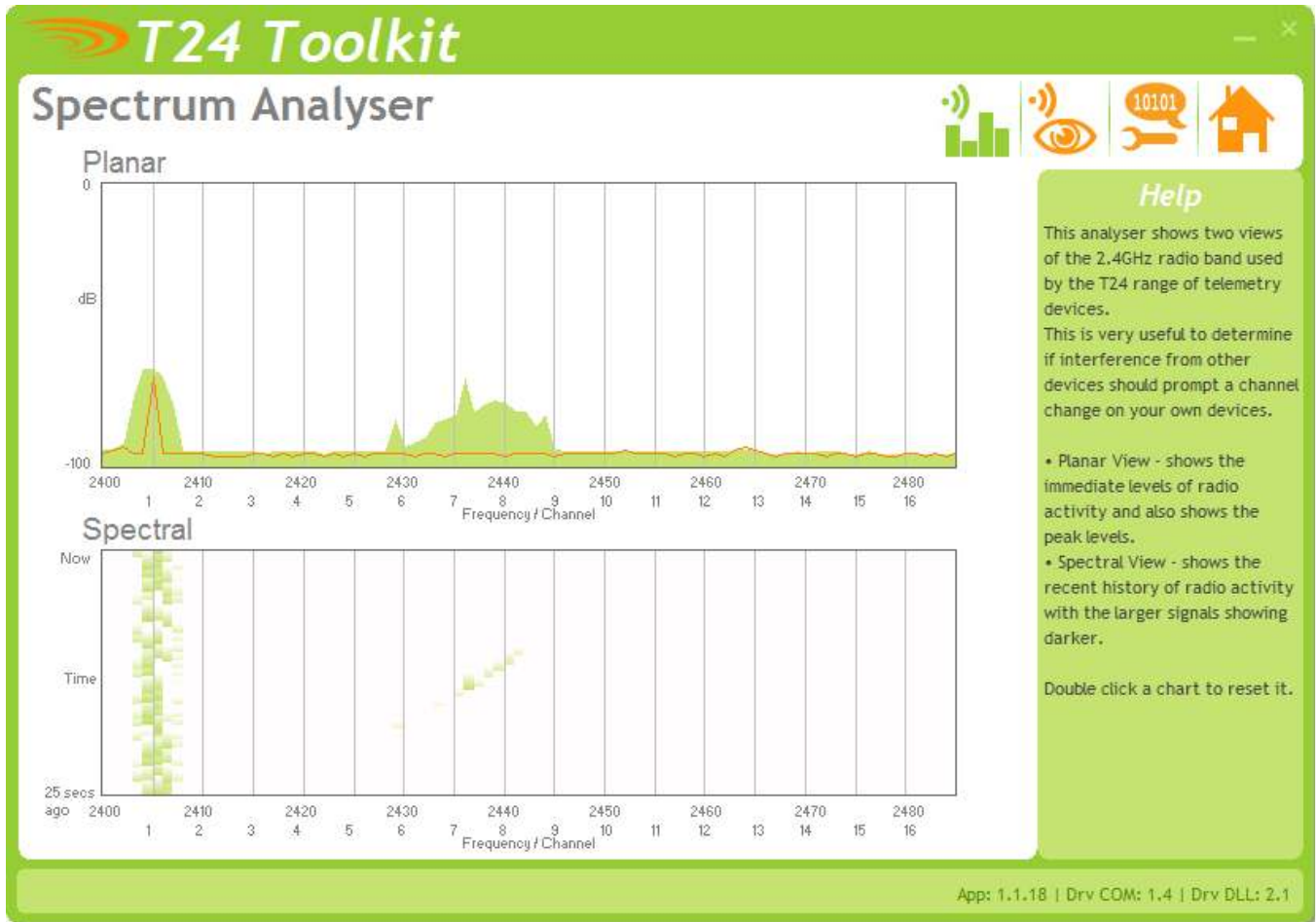

The analyser page is provided as a tool and will not normally be needed unless you plan to change channels and want to find the best channel to select, or to diagnose poor communications issues.

This page shows the radio signal levels detected across all the channels available to the T24 series of devices. Using this tool may help in detecting noisy areas and allow you to decide on which channels you may want to use.

The above charts show the traffic from a Wi-Fi network and it can be seen to be operating over channels 6 to 9 and it would be best (though not essential) to avoid using these channels.

## Information

**T24 Toolkit**

### Information

Analogue Output 1

ID: FFCBB0  
Model: T24-A01  
Firmware Version: 1.01  
Radio Module Firmware Version: 1.8  
Name: [redacted]

#### Help

Here you can view information about the device. You can also allocate a descriptive name to aid future identification.

Pressing F1 or double-clicking the module image will display the T24-A01 manual if it can be located.

Connected to T24-A01 of ID FFCBB0 on channel 1

App: 1.1.18 | Drv COM: 1.4 | Drv DLL: 2.1

This page shows you information about the connected device.

#### Items you can change:

**Name** You can enter a short descriptive name (11 characters) which may help you recognise this device in the future.

## Channel and Encryption

**Channel**  
01 You can select 1 of 16 channels

**Encryption Key**  
00000000000000000000000000000000

The encryption key is 32 hex characters long.  
Characters allowed are 1234567890ABCDEF

NOTE: Changing the channel and key will not affect the device until it has been power cycled.

If you have a handheld device and one or more acquisition devices and you want to change the channel and keys for all you could do either of the following:

- Connect this toolkit to each of the devices in turn and change the channel and key settings.
- Connect to just the handheld device and set the channel and key as required. Next using the pair function in the handheld connect to each acquisition device to change its settings to match those of the handheld.
- Connect to one device and change its channel and key as required. Click the Home button and then re-pair to that device. The base station will now match its settings to that device. Return to this page and click the Advanced button. From here you will be able to quickly change the settings of multiple devices to match the base station just by pairing with each one in turn.

Advanced

Help  
Here you can change the channel and encryption key for the connected device.

NOTE: The device will need power cycling before these changes take effect. If you power cycle the device you will need to click the HOME button and pair the device again with this application.

Connected to T24-AO1 of ID FFCBB0 on channel 1

App: 1.1.18 | Drv COM: 1.4 | Drv DLL: 2.1

Here you can change the channel and encryption key for the module.

NOTE: Early T24 modules do not yet utilise the encryption keys so these should be left at all zeros.

### Items you can change:

Channel

Select a channel between 1 and 16. The default is channel 1. You can use the Spectrum Analyser mode to determine a good clean channel to use.  
NOTE: Channel 16 is used to negotiate pairing so avoid this channel if possible.

Encryption Key

Only devices with identical encryption keys can communicate. You can isolate groups of devices on the same channel or just use the key to ensure the data cannot be read by somebody else.

## Save and Restore



Here you can save the device settings to a file on your PC so that they can be later loaded back into the same or different device.

### Items you can change:

- |                   |   |
|-------------------|---|
| Save              | Click this button to open a file dialog window to allow you to select a filename and location to save the configuration file to.<br>All configuration information including calibration data will be saved to the file.<br>The file extension is tcf.                             |
| Restore           | Click this button to open a file dialog window to allow you to select a filename and location of a previously saved file to load into the connected device.<br>All configuration information <b>including</b> calibration data will be overwritten.<br>The file extension is tcf. |
| Advanced Settings | Click this button to enter the Advanced Settings Page.<br>Here are settings which do not normally require changing.   |

## Input / Output Config

**T24 Toolkit**

### Input / Output Config

**Input**

**In Minimum**  
-50.0  
Enter the engineering unit value supplied to this device that will cause the analogue output to operate at 0%. i.e. with a -10V to +10V output 0% would be -10V.

**In Maximum**  
50.0  
Enter the engineering unit value supplied to this device that will cause the analogue output to operate at 100%. i.e. with a -10V to +10V output 100% would be +10V.

**Input Value**  
1.2052870  
Shows the current input value supplied by the acquisition device.  
[Format](#)

**Output**

**Smoothing**  
No  
Turn this option on to smooth the analogue output where possible.

**Current Selected Output** Shows the current output range selected by the jumper links.  
4 to 20mA (sink)

**Help**  
Here you determine how the input affects the output.

Connected to T24-AO1 of ID FFCA48 on channel 10 App: 1.1.19 | Drv COM: 1.4 | Drv DLL: 2.1

Here you set the properties that determine the input and output relationship.

### Items you can change:

#### Input

##### In Minimum

Enter the input value that should result in the minimum output. The minimum output depends on the Current Selected Output which is determined by the SW2 DIP switch settings.

Range	Minimum Output
0-10 V	0 V
+/-10 V	-10 V
0-5 V	0 V
+/-5 V	-5 V
0-20 mA Sink	0 mA
0-20 mA Source	0 mA
4-20 mA Sink	4 mA
4-20 mA Source	4 mA

In maximum

Enter the input value that should result in the maximum output. The maximum output depends on the Current Selected Output which is determined by the SW2 DIP switch settings.

Range	Minimum Output
0-10 V	10 V
+/-10 V	10 V
0-5 V	5 V
+/-5 V	5 V
0-20 mA Sink	20 mA
0-20 mA Source	20 mA
4-20 mA Sink	20 mA
4-20 mA Source	20 mA

Input value

This shows the currently supplied value to the T24-AO1. An active acquisition module must be in place to view this value.

Click Format to select a display format.

**Output**

Smoothing

Click here to select whether to apply smoothing to the output.

The analog output is updated at a rate of 2KHz.

When no smoothing is applied the output changes as soon as new data arrives from the acquisition module.

When smoothing is active the output is ramped between the last input value and the current input value at a rate of 2KHz. This has the effect of delaying the output (latency) by the interval between values being delivered to the input. i.e. The T24-AO1 must receive an input value then start to ramp up to it from the previous input value.

Example: with an acquisition module delivering data at 3Hz the T24-AO1 output would have a latency of 333ms when smoothing is active.

Current Selected Output

This shows the currently selected output range as set by the SW2 DIP switches. NOTE: Some of the DIP switches are used to indicate to the device the selected range and others are used to route circuitry so although this display may indicate the selected range that does not mean that all switches are in the correct position for the range to work correctly. Always check the SW2 DIP switch table for the correct settings.

## Alarm Settings

**Timeout (ms)**  
1000 Enter the timeout in milliseconds after which time elapses with no data arriving will trigger the TimeoutAction.

**Timeout Action**  
4-Maximum Output Select what action to take if data does not arrive within the timeout period set above. This action will change the analogue output to the selected level.

**Remote Error Action**  
1-Minimum Full Scale Select what action to take if remote paired device reports an error. This action will change the analogue output to the selected level.

**Remote Batt Action**  
6-Hold Last Output Select what action to take if remote paired device reports battery low. This action will change the analogue output to the selected level.

**Error State**  
None Shows the current error state.

**Help**  
Set the actions to execute when errors occur or communications is lost. These actions determine the state of the analogue output.

Connected to T24-AO1 of ID FFCBB0 on channel 1 App: 1.1.18 | Drv COM: 1.4 | Drv DLL: 2.1

Here you can set the action to take when certain errors occur.

The actions are applied when the errors occur and if more than one error is present the actions are applied with the following priorities:

Timeout Action, Remote Error Action, Remote Batt Action

When errors are removed the analog output resumes reflecting the current input.

### Items you can change:

- |                     |   |
|---------------------|---|
| Timeout             | Enter the timeout in milliseconds for the input to timeout. If a new Data Provider packet does not arrive within this time the <b>Timeout Action</b> will trigger. Generally this timeout should be set to at least three times the acquisition module transmission rate.                                 |
| Timeout Action      | Select the action to take place when a timeout occurs. i.e. when communications (for more than the duration of the Timeout value) is lost with the acquisition module.<br>See the <b>Output Actions</b> section for the available actions and the effect of these choices on the different output ranges. |
| Remote Error Action | Acquisition modules can report errors. You will need to refer to the module manual for information regarding what constitutes an error.<br>See the <b>Output Actions</b> section for the available actions and the effect of these choices on the different output ranges.                                |
| Remote Batt Action  | When the acquisition module reports a low battery this action will occur.<br>See the <b>Output Actions</b> section for the available actions and the effect of these choices on the different output ranges.  |

## Output Actions

The following actions can be selected.

<b>None</b>	Do nothing
<b>Minimum Full Scale</b>	Set analog output to the minimum full scale value
<b>Maximum Full Scale</b>	Set analog output to the maximum full scale value
<b>Minimum Output</b>	Set analog output to the minimum possible value
<b>Maximum Output</b>	Set analog output to the maximum possible scale value
<b>Half Full Scale</b>	Set analog output to halfway between minimum and maximum full scale value
<b>Hold Last Output</b>	Hold the last output. (Does the same as None for the <b>Timeout Action</b> )

The following table shows the output that can be expected for each range.

Action	Output Range					
	0-10 V	+/-10 V	0-5 V	+/-5 V	0-20 mA	4-20 mA
None	-	-	-	-	-	-
Minimum Full Scale	0	-10	0	-5	0	4
Maximum Full Scale	10	10	5	5	20	20
Minimum Output *	-0.5	-11	-0.3	-5.5	0	0
Maximum Output *	11	12	5.4	6	22.4	22.4
Half Full Scale	5	0	2.5	0	10	12
Hold Last Output	-	-	-	-	-	-

\* The values shown here are approximate. Each device will vary depending on tolerances of electronic components.



## Zero Settings

**T24 Toolkit**

### Zero

**Perform System Zero**

You can perform a system zero now by [Clicking Here](#) or remove any existing system zero by [Clicking Here](#) NOTE: the device must be receiving data from its paired acquisition module.

**System Zero**

Enter the system zero value manually.

**Help**

Set or remove the system zero.

This function is used to zero the input values supplied by the paired acquisition module. Note that this may not necessarily zero the analog output.

For this function to work correctly the acquisition module needs to be supplying data to this module. Note that at very high speeds the acquisition device may obstruct the communications of this toolkit.

In cases where data is being supplied at very high rates you may need to use the digital input to set system zero. Please refer to the user manual.

Connected to T24-AO1 of ID FFCBB0 on channel 1 App: 1.1.18 | Drv COM: 1.4 | Drv DLL: 2.1

System zero allows you to zero the input. The system zero value is subtracted from the input value before it is used to determine the analog output to apply.

**NOTE: Performing a System Zero does not necessarily zero the output!**

This page allows either manual entry or to zero the current input value.

#### Items you can change:

- |                     |   |
|---------------------|---|
| Perform System Zero | Click to use the current input value as the new system zero.                                    |
| Remove System Zero  | Remove the system zero so that the input value is directly used to determine the analog output. |
| System Zero         | Enter the required system zero value.   |

## Advanced Settings

**T24 Toolkit**  
Advanced Settings

**Pair Wait Duration (s)**  
5 This determines how long to wait in seconds when pairing an acquisition device to this one. Pairing is triggered from a button press on the device. The default is 5 seconds.

**Paired Data Tag**  
C99A If you want to pair devices manually then enter the Data Tag of the paired acquisition module.

**Paired ID**  
FFC99A Enter the ID of the paired acquisition module. (Required to wake the module).

**Waker Duration (ms)**  
12000 Select how long the handheld will wait to wake the paired module on power up. The default is 12 seconds (12000 ms). NOTE: The paired module should have a SleepDelay set so once this device is powered down the paired device will automatically sleep. Recommended SleepDelay is 10 seconds.

**Help**  
These are advanced settings and do not normally require changing.

Connected to T24-AO1 of ID FFD042 on channel 8 App: 1.1.76 | Drv COM: 1.6 | Drv DLL: 2.4

This page allows effective conversion between units. i.e. Although all devices supplying data are configured in Kg you can get a printed output in Lbs.

### Items you can change:

Pair Wait Duration	Here you can set the duration that the T24-AO1 will wait to achieve successful pairing after the Pair Switch is pressed. The default is 5 seconds.
Paired Data Tag	This shows the currently paired Data Tag. You can click this to manually enter a Data Tag.
Paired ID	Version 1.1 onwards. This shows the ID of the paired module. This is required if the analog output device is to wake the acquisition module when it is first powered on.
Waker Duration (ms)	Version 1.1 onwards. To wake the paired acquisition module on powerup and to keep it awake you need to enter a time to try waking the module in milliseconds. The default is 12000 ms (12 seconds). Enter zero to disable the automatic waking of modules. NOTE: The paired acquisition module should have its SleepDelay parameter set so that once the analog output device is turned off the remote module will go back to sleep on its own. The recommended time for the sleep delay is 10 seconds or 10000 ms.

# Specifications

## General Radio

	Min	Typical	Max	Units
License		License Exempt		
Modulation method		MS (QPSK)		
Radio type		Transceiver (2 way)		
Data rate		250		k bits/sec
Radio Frequency	2.4000		2.4835	GHz
Power		1		mw
Range T24-AO1			100 (325)	Metres (feet) *
Range T24-AO1i (External antenna)			200 (650)	Metres (feet) *
Channels (DSSS)		16		

\* Maximum range achieved in open field site with T24-SA at a height of 3 metres (9.8 feet) above ground.

## T24-AO1

Parameter	Minimum	Typical	Maximum	Units	Notes
External Supply voltage Range	9	12	36	Volts	
Operational Current	-	85	150	mA	
Operating Temperature Range	-40	-	85	Deg C	
Storage Temperature Range	-40	-	85	Deg C	
Reverse polarity Protection	-	-	-36	Volts	Maximum Supply level
Digital output Drive voltage			30	Volts	
Digital output Drive Current			20	mA	
Source Impedance driving Digital Input (volt-free contact)			200	Ohms	
<b>Voltage output</b>					
Resolution		16		Bits	
output gain stability	-	0.008	0.015	± % FS/ °C	
output zero stability	-	0.005	0.015	± % FS/ °C	
Short term stability (1 hr)	-	0.003	0.01	± % FS	
Long term stability (10k hrs)	-	0.03	0.1	± % FS	
Residual ripple		40		mV p-p	
Minimum load impedance	5000			Ohms	
Linearity	-	0.007	0.01	± % FS	
<b>Current output</b>					
Resolution		16		Bits	
4-20mA output gain stability	-	0.006	0.03	± % FS/ °C	
4-20mA output zero stability	-	0.003	0.02	± % FS/ °C	
Short term stability (1 hr)	-	0.006	0.03	± % FS	
Long term stability (10k hrs)	-	0.06	0.2	± % FS	
Residual ripple		0.032		mA p-p	
Settling time to ±0.5uA (thermal effects)	-	5	-	secs	
Maximum load impedance			500	Ohms	
Linearity	-	0.01	0.02	± % FS	
<b>Physical Dimensions</b>					
T24-AO1	166 X 87 X 26 mm				
T24-AO1i	190 X 80 X 55 mm				

## Physical Dimensions

### T24-A01

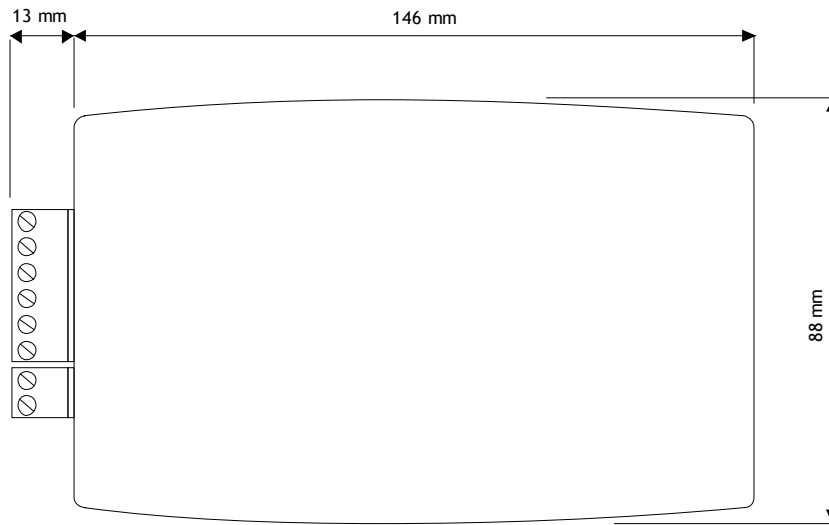

### T24-A01i

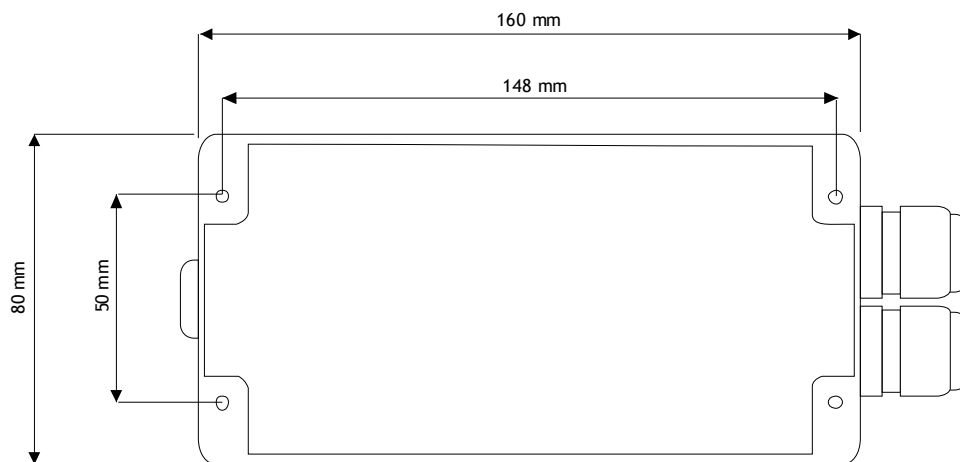

## Installation

### Overview

Radio performance at microwave wavelengths is very dependent upon the operating environment; any structure within the operating region of the radios will give rise to three effects:

**Obscuration.** Obscuration will result in reduced range and occurs when an obstruction masks the line-of-sight between radios.

**Aberrations to the horizontal and vertical space patterns.** Distortion of these patterns may occur if structures or objects are placed in the near or intermediate field of the antenna. The effect will be to distort the coverage patterns, adversely affecting range and link quality.

**Reflection.** Any object placed in line-of-sight of the transmit antenna will result in signals arriving at the receiver by an indirect path. Degradation of performance due to reflection (multipath effects) appears as reduced range or poor link quality.

Any of the above will cause poor RSSI figures, an increase in the packet loss rate and in extreme cases complete loss of signal. Fortunately, if consideration is given to these effects at the integration stage then a good quality link will be obtained.

#### **Guidelines for product design:**

When selecting materials for product enclosures, preference should be given to fibreglass, light coloured ABS or Polypropylene; at the wavelength of 2.4GHz radio other materials will adversely affect the signal by attenuation, refraction or change in polarisation.

If the application demands that the radio is fitted inside a metal enclosure then ensure that the specified clearances are maintained around the antenna and design in a fibreglass RF window at least as large as the clearance dimensions but ideally as large as possible.

RAD24i radios fitted inside a product should be oriented so that the chip antenna will be vertical when the product is in its normal operating position.

#### **Guidelines for installation:**

When planning installations ensure that line-of-sight between nodes is maintained and that objects or structures are kept at least one metre away from antennae wherever possible.

To avoid poor link quality between a RAD24i radio and a handheld device ensure that the RAD24i is mounted so that the chip antenna is vertical. Improvement may also be obtained by altering the height above ground of the RAD24i; a small increase or reduction in antenna elevation will often improve reception.

Range underwater is only a decimetre or so depending on packet rate. Best performance underwater is obtained by using low packet rates and immersing water-proofed antennae rather than water-tight enclosures containing the antennae.

## Approvals

### CE



Complies with EMC directive. 2004/108/EC  
The Radio Equipment and Telecommunications Terminal Equipment (R&TTE) Directive,  
1999/5/EC,

#### European Community, Switzerland, Norway, Iceland, and Liechtenstein

- English: This equipment is in compliance with the essential requirements and other relevant provisions of Directive 1999/5/EC.
- Deutsch: Dieses Gerät entspricht den grundlegenden Anforderungen und den weiteren entsprechenden Vorgaben der Richtlinie 1999/5/EU.
- Dansk: Dette udstyr er i overensstemmelse med de væsentlige krav og andre relevante bestemmelser i Direktiv 1999/5/EF.
- Español: Este equipo cumple con los requisitos esenciales así como con otras disposiciones de la Directiva 1999/5/EC.
- Français: Cet appareil est conforme aux exigences essentielles et aux autres dispositions pertinentes de la Directive 1999/5/EC.
- Íslenska: Þessi búnaður samrýmist lögboðnum kröfum og öðrum ákvæðum tilskipunar 1999/5/ESB.
- Italiano: Questo apparato è conforme ai requisiti essenziali ed agli altri principi sanciti dalla Direttiva 1999/5/EC.
- Nederlands: Deze apparatuur voldoet aan de belangrijkste eisen en andere voorzieningen van richtlijn 1999/5/EC.
- Norsk: Dette utstyret er i samsvar med de grunnleggende krav og andre relevante bestemmelser i EU-direktiv 1999/5/EC.
- Português: Este equipamento satisfaz os requisitos essenciais e outras provisões da Directiva 1999/5/EC.
- Suomalainen: Tämä laite täyttää direktiivin 1999/5/EY oleelliset vaatimukset ja on siinä asetettujen muidenkin ehtojen mukainen.
- Svenska: Denna utrustning är i överensstämmelse med de väsentliga kraven och andra relevanta bestämmelser i Direktiv 1999/5/EC.

This equipment is in compliance with the essential requirements and other relevant provisions of Directive 1999/5/EC.

### FCC



Family: RAD24

Models: i and e for internal and external antenna variants. For antenna T24-ANTA and T24-ANTB

FCC ID:VHARAD24

This device complies with Part 15c of the FCC Rules. Operation is subject to the following two conditions: (1) this device may not cause harmful interference, and (2) this device must accept any interference received, including interference that may cause undesired operation.

**CAUTION:** If the device is changed or modified without permission from Mantracourt Electronics Ltd, the user may void his or her authority to operate the equipment.

### Industry Canada



Industry Industrie  
Canada Canada

Models: i and e for internal and external antenna variants. For antenna T24-ANTA and T24-ANTB

IC:7224A-RAD24

This apparatus complies with RSS-210 - Low-power Licence-exempt Radiocommunication Devices (All Frequency Bands): Category I Equipment RSS.

## OEM / Reseller Marking and Documentation Requirements

### FCC

The Original Equipment Manufacturer (OEM) must ensure that FCC labelling requirements are met. This includes a clearly visible label on the outside of the final product enclosure that displays the contents as shown:

Contains FCC ID:VHARAD24

This device complies with Part 15 of the FCC Rules. Operation is subject to the following two conditions:

- (1) this device may not cause harmful interference and
- (2) this device must accept any interference received, including interference that may cause undesired operation.

The acquisition modules have been tested with T24-ANTA and T24-ANTB. When integrated in OEM products, fixed antennas require installation preventing end-users from replacing them with non-approved antennas. Antennas other than T24-ANTA and T24-ANTB must be tested to comply with FCC Section 15.203 (unique antenna connectors) and Section 15.247 (emissions).

Acquisition modules have been certified by the FCC for use with other products without any further certification (as per FCC section 2.1091). Changes or modifications not expressly approved by Mantracourt could void the user's authority to operate the equipment.

In order to fulfil the certification requirements, the OEM must comply with FCC regulations:

1. The system integrator must ensure that the text on the external label provided with this device is placed on the outside of the final product.
2. The acquisition modules with external antennas may be used only with Approved Antennas that have been tested by Mantracourt.

### IC

Labelling requirements for Industry Canada are similar to those of the FCC. A clearly visible label on the outside of the final product enclosure must display the following text:

Contains Model RAD24 Radio (2.4 GHz), IC:7224A-RAD24

Integrator is responsible for its product to comply with RSS-210 - Low-power Licence-exempt Radiocommunication Devices (All Frequency Bands): Category I Equipment RSS.

### CE

The T24 series has been certified for several European countries.

If the acquisition module is incorporated into a product, the manufacturer must ensure compliance of the final product to the European harmonized EMC and low-voltage/safety standards. A Declaration of Conformity must be issued for each of these standards and kept on file as described in Annex II of the R&TTE Directive. Furthermore, the manufacturer must maintain a copy of the T24 device user manual documentation and ensure the final product does not exceed the specified power ratings, antenna specifications, and/or installation requirements as specified in the user manual. If any of these specifications are exceeded in the final product, a submission must be made to a notified body for compliance testing to all required standards.

#### OEM Labelling Requirements

The 'CE' marking must be affixed to a visible location on the OEM product.



The CE mark shall consist of the initials "CE" taking the following form:

- If the CE marking is reduced or enlarged, the proportions given in the above graduated drawing must be respected.
- The CE marking must have a height of at least 5mm except where this is not possible on account of the nature of the apparatus.
- The CE marking must be affixed visibly, legibly, and indelibly.

## Declaration of Conformity

We, Mantracourt Electronics Limited  
The Drive  
Farringdon  
Exeter  
Devon EX5 2JB

declare under our sole responsibility that our products in the **T24 Radio Telemetry Product Range** to which this declaration relates are in conformity with the appropriate standard EN 300 328 following the provisions of the Radio and Telecommunications Terminal Equipment Directive **1999/5/EC**, FCC CFR Title 47 part 15c BS EN 61000-4-2 and BS EN 61000-4-3 following the provisions of the EMC Directive **2004/108/EC** and Low Voltage Directive **2006/95/EC**.

December 2007



Brett James  
Development Manager  
Mantracourt Electronics Limited.

FCC ID:VHARAD24



## Worldwide Regional Approvals

Region	Product Conforms To
Europe	CE
USA	FCC
Canada	IC
Australia	To Be Determined
China	To Be Determined
Japan	To Be Determined

### Important Note

Mantracourt does not list the entire set of standards that must be met for each country. Mantracourt customers assume full responsibility for learning and meeting the required guidelines for each country in their distribution market. For more information relating to European compliance of an OEM product incorporating the T24 range of modules, contact Mantracourt, or refer to the following web site: [www.ero.dk](http://www.ero.dk)

### Warranty

All Telemetry products from Mantracourt Electronics Ltd., ('Mantracourt') are warranted against defective material and workmanship for a period of (1) one year from the date of dispatch.

If the 'Mantracourt' product you purchase appears to have a defect in material or workmanship or fails during normal use within the period, please contact your Distributor, who will assist you in resolving the problem. If it is necessary to return the product to 'Mantracourt' please include a note stating name, company, address, phone number and a detailed description of the problem. Also, please indicate if it is a warranty repair.

The sender is responsible for shipping charges, freight insurance and proper packaging to prevent breakage in transit.

'Mantracourt' warranty does not apply to defects resulting from action of the buyer such as mishandling, improper interfacing, operation outside of design limits, improper repair or unauthorised modification.

No other warranties are expressed or implied. 'Mantracourt' specifically disclaims any implied warranties of merchantability or fitness for a specific purpose. The remedies outlined above are the buyer's only remedies. 'Mantracourt' will not be liable for direct, indirect, special, incidental or consequential damages whether based on the contract, tort or other legal theory. Any corrective maintenance required after the warranty period should be performed by 'Mantracourt' approved personnel only.



In the interests of continued product development, Mantracourt Electronics Limited reserves the right to alter product specifications without prior notice.  
DESIGNED & MANUFACTURED IN THE UK

Code No. 517-181

Issue 1.2

11.08.10